

# Principal Features of MELDIN® 7000

## Geometric Stability at High Temperature

MELDIN® 7000 series of materials exhibit extremely high geometric stability at elevated temperatures. Testing has shown MELDIN® 7000 to have less than 0.04% variation from its original dimensions after cycling from 73°F (22.77°C) to 500°F (260°C) over a 2 day period.

## Total Process Control... Powder-to-Parts

Our expanding resin production facility and our R&D testing labs allow Saint-Gobain Performance Plastics to maintain control of the quality and source of the base polyimide resin. Our "Powder-to-Parts" capability means total process control of resin production, stock shape manufacturing, direct forming, and critical dimensional machining of your finished parts.

## Longer Life at Higher Loads and Speeds

The self-lubricating grades of MELDIN® 7000 do not melt when exposed to high load (P), or high speed (V) applications, as compared to more traditional PTFE or thermoplastic polymers. P x V limits for MELDIN® 7000 self-lubricating grades exceeded 300,000 in dry environments and past 1,000,000 in liquid or grease lubricated environments.



## Technical Graphs

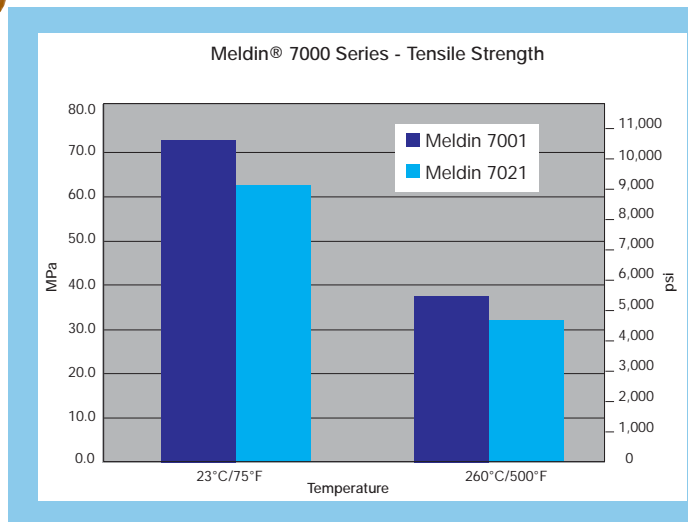

# MELDIN<sup>®</sup> 7000 Compounds



## MELDIN<sup>®</sup> 7001, Unfilled Grade

A thermosetting polyimide, MELDIN<sup>®</sup> 7001 is our unfilled base resin. This grade offers the maximum mechanical properties and high chemical resistance. The MELDIN<sup>®</sup> 7001 grade is ideal for electrical and thermal insulating applications. More ductile than ceramics, and lighter weight than metals, MELDIN<sup>®</sup> 7001 is a popular choice for structural parts in aerospace and other applications where metal replacement is desirable.

## MELDIN<sup>®</sup> 7021, Self-Lubricating Grade

Our self-lubricating grade, MELDIN<sup>®</sup> 7021, has 15% by weight graphite fillers, encapsulated by the base polyimide resin. With its low coefficient of friction and high heat resistance, MELDIN<sup>®</sup> 7021 provides our customers the best all-around choice for high temperature bearings, seals, and other low-wear applications.

### Product availability:

- Basic shapes
- Finished parts

### Mfg processes:

- Compression Moulding
- Injection Moulding
- Direct forming
- Machined parts

Meldin<sup>®</sup> 7000 Series - Elongation

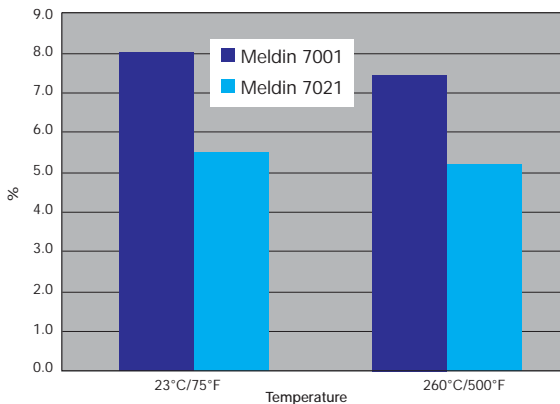

Coefficient of Friction

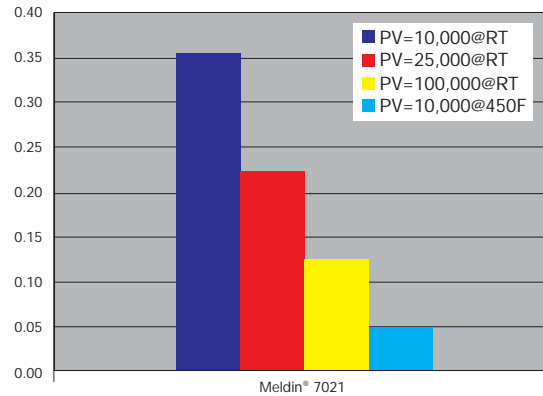

# Applications of MELDIN® 7000

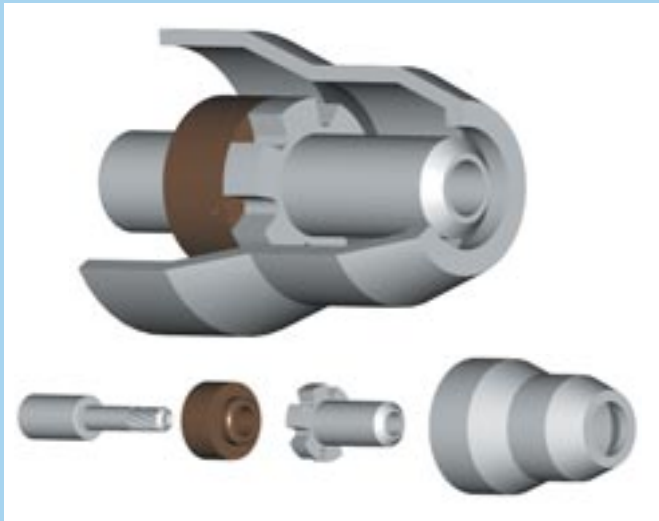

MELDIN® 7001 materials are direct formed and machined for use in critical plasma cutting torches in the torch handle. These torches create high energy vortex gas streams, and MELDIN® 7000 parts distribute these gases precisely due to their inherent dimensional stability and machinability. Also, other parts in the torch handle insulate high electrical energy from the user ensuring safe operation. High impact resistance increases the useful life of this equipment as compared to ceramic alternatives.

Our Meldin 7021 self-lubricating polyimide materials meet or exceed the most stringent requirements for aerospace applications. Backed up by third-party independent testing, the Meldin 7021 material grade provide our customers consistent mechanical and performance properties for aircraft airframe systems such as landing gear and fuselage components, as well as jet engine parts such as pads, bumpers, washers, seals, and bearings.



Semi-conductor manufacturing customers require process equipment whose materials have high purity, high resistance to solvents, oils, and other process chemicals, and high electrical insulative properties — all combined with the ability to hold dimensional features over a wide temperature range. The Meldin® 7001 unfilled resin grade fulfills all these requirements. Available as finished machined parts, or in basic shapes (ask about our 12"x12" plates), Meldin® 7001 will add value to your production.

# Typical Properties of MELDIN<sup>®</sup> 7000

PROPERTY	TEST METHOD	ENGLISH (METRIC)	MELDIN <sup>®</sup> 7001	MELDIN <sup>®</sup> 7021
<b>MECHANICAL @ RT</b>				
Tensile Strength	ASTM D638	psi (MPa)	10,500 (72.4)	9,100 (63)
Elongation	ASTM D638	%	8.0	5.5
Flexural Strength	ASTM D790	psi (MPa)	12,800 (88)	13,000 (89.5)
Flexural Modulus	ASTM D790	psi x 10 <sup>5</sup> (GPa)	3.65 (2.5)	4.5 (3.1)
Compressive Stress @ 1% Strain	ASTM D695	psi (MPa)	3,800 (26)*	3,400 (23)
Compressive Stress @ 10% Strain	ASTM D695	psi (MPa)	18,500 (127.5)*	15,300 (106)
Compressive Modulus	ASTM D695	psi x 10 <sup>5</sup> (GPa)	4.0 (2.8)*	3.0 (2.1)
Coefficient of Thermal Expansion 73 – 500 °F (23 – 260 °C)	ASTM E831	in/in/°F (m/m/°C) x 10 <sup>-5</sup>	2.7 (4.86)	2.5 (4.5)
Thermal Conductivity	ASTM F433	BTU in/hr ft <sup>2</sup> °F (W/m °C)	2.15 (0.31)	—
<b>ELECTRICAL</b>				
Dielectric Strength				
Short time 2 mm (.08" ) thick	ASTM D149	V/mil (MV/m)	580 (22.9)	280 (11)*
Dielectric Constant 100 Hz*	ASTM D150	—	3.18	—
Dielectric Constant 10 kHz*	ASTM D150	—	3.16	—
Dielectric Constant 1 MHz*	ASTM D150	—	3.14	—
<b>OTHER</b>				
Specific Gravity	ASTM D792	—	1.34	1.42
Hardness Rockwell E*	ASTM D785	—	45-55*	36
Water Absorption, 24 hours*	ASTM D570	%	0.23*	0.19*
Water Absorption , 48 hours*	ASTM D570	%	0.6*	0.50*
Coefficient of Friction @ 25000 PV = 250 psi x 100 fpm	ASTM D3702	—	0.25	0.23
Coefficient of Friction @ 100000 PV = 500 psi x 200 fpm	ASTM D3702	—	0.27	0.12
High Temperature Dimensional Stability @ 500 °F (260 °C)	INTERNAL	% Change	—	0.04% Max
<b>Mechanical @500°F (260°C)</b>				
Tensile Strength	ASTM D638	psi (MPa)	5,500 (38)	4,700 (32)
Elongation	ASTM D638	%	7.5	5.2
Flexural Strength	ASTM D790	psi (MPa)	7000 (48)	7,500 (52)
Flexural Modulus	ASTM D790	psi x 10 <sup>5</sup> (GPa)	2.0 (1.3)	2.64 (1.8)

Data Obtained from Direct formed samples, except as noted.

\*Meldin Compression molded sample