

Conveying Components

Industrial Chain Guides for Roller Chains

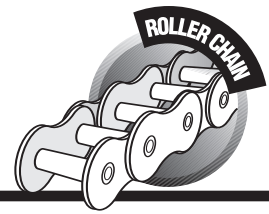

TIVAR industrial chain guides are available in TIVAR 1000, which meets guidelines for food handling, including those from FDA, USDA and 3-A Dairy. TIVAR's self-lubricating surface minimizes friction and extends chain life.

Chain guide standards:

- 10-foot lengths
- single- and double-strand chain
- natural

Custom colors and triple-strand designs also available



Figure A

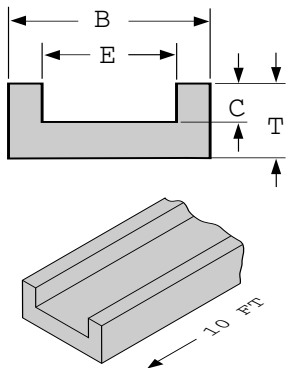

TIVAR Chain Guide

Catalog No.	Figure desc.	ASA Chain No.	T Min. (in.)	B Min. (in.)	C (in.)	D (in.)	E (in.)	F (in.)
EUHC1040	A	2040	5/16	1-1/4	1/8	-	7/8	-
EUHC1050		2050	3/8	1-1/4	5/32	-	1	-
EUHC1060		2060	3/8	1-1/2	3/16	-	1-1/4	-
EUHC1080		2080	1/2	2	1/4	-	1-9/16	-
EUHC1100		2100	5/8	2-1/4	5/16	-	1-7/8	-
EUHC1120		2120	5/8	2-3/4	3/8	-	2-1/4	-
EUHC1003		H78/S188	1-1/4	4-1/4	7/8	-	3-1/2	-
EUHC1004		81X/1578	1	3	5/8	-	2-1/2	-

Figure B

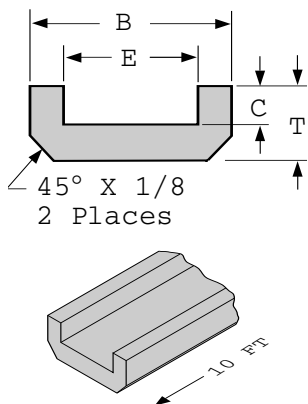

TIVAR Chain Guide

Catalog No.	Figure desc.	ASA Chain No.	T Min. (in.)	B Min. (in.)	C (in.)	D (in.)	E (in.)	F (in.)
EUHC0040	B	2040	5/16	1-1/4	1/8	-	7/8	-
EUHC0050		2050	3/8	1-1/4	5/32	-	1	-
EUHC0060		2060	3/8	1-1/2	3/16	-	1-1/4	-
EUHC0080		2080	1/2	2	1/4	-	1-9/16	-
EUHC0100		2100	5/8	2-1/4	5/16	-	1-7/8	-
EUHC0120		2120	5/8	2-3/4	3/8	-	2-1/4	-

Conveying Components

Industrial Chain Guides for Roller Chains

- USDA/FDA/3-A Dairy approved
- Quiet: reduces noise
- For use with plastic or metal chain

Figure C

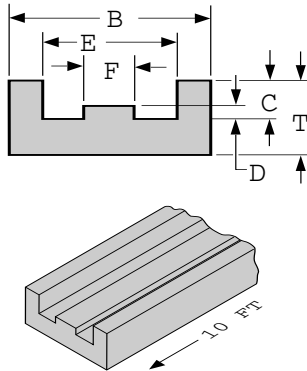

TIVAR Chain Guide

Catalog No.	Figure desc.	ASA Chain No.	T Min. (in.)	B Min. (in.)	C (in.)	D (in.)	E (in.)	F (in.)
EUHC2040	C	2040	5/16	1	0.140	0.080	11/16	1/4
EUHC2050		2050	3/8	1-1/4	3/16	0.100	13/16	5/16
EUHC2060		2060	1/2	1-1/2	0.213	0.115	1-1/8	7/16
EUHC2080		2080	1/2	2	1/4	0.130	1-7/16	9/16

Figure D

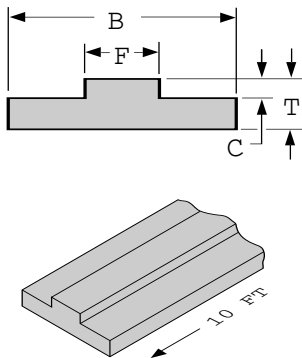

TIVAR Chain Guide

Catalog No.	Figure desc.	ASA Chain No.	T Min. (in.)	B Min. (in.)	C (in.)	D (in.)	E (in.)	F (in.)
EUHC5040	D	2040	5/16	1	0.080	-	-	1/4
EUHC5050		2050	5/16	1-1/4	0.100	-	-	5/16
EUHC5060		2060	5/16	1-1/4	0.115	-	-	7/16
EUHC5080		2080	3/8	1-1/2	0.130	-	-	9/16
EUHC5100		2100	1/2	2	0.210	-	-	11/16
EUHC5120		2120	1/2	2-1/4	0.260	-	-	15/16

Figure E

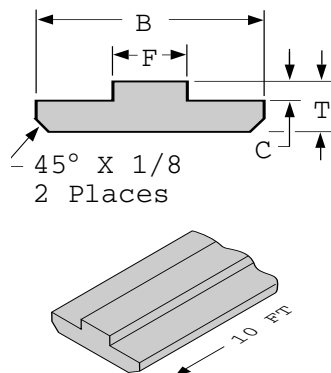

TIVAR Chain Guide

Catalog No.	Figure desc.	ASA Chain No.	T Min. (in.)	B Min. (in.)	C (in.)	D (in.)	E (in.)	F (in.)
EUHC6040	E	2040	5/16	1	0.080	-	-	1/4
EUHC6050		2050	5/16	1-1/4	0.100	-	-	5/16
EUHC6060		2060	5/16	1-1/4	0.115	-	-	7/16
EUHC6080		2080	3/8	1-1/2	0.130	-	-	9/16
EUHC6100		2100	1/2	2	0.210	-	-	11/16
EUHC6120		2120	1/2	2-1/4	0.260	-	-	15/16

Conveying Components

UltraTrac Chain Guides for Roller Chains

- Sanitary: USDA/FDA
- Extends Chain Life
- Minimizes Friction
- Quiet: Reduces Noise
- Cost-Effective

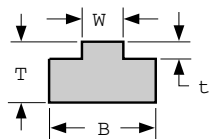
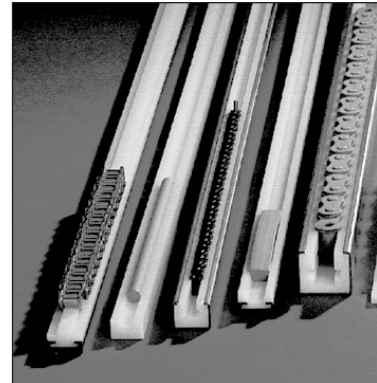

Type T

FIG. A

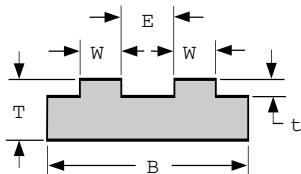
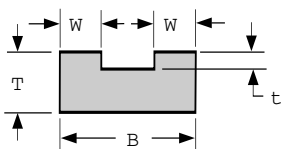

FIG. B



Type TD

Type T • For ANSI Standard Roller Chain

Catalog No.	ANSI Chain #	B	T	W	t
EUHU2825	25	.78	.59	.10	.09
EUHU2835	35	.78	.59	.17	.10
EUHU2840	40	.78	.59	.29	.10
EUHU2850	50	.78	.59	.35	.12
EUHU2860	60	1.10	.59	.47	.15
EUHU2880	80	1.34	.71	.60	.18
EUHU2810	100	1.61	1.00	.72	.26
EUHU2812	120	2.01	1.25	.96	.31
EUHU2814	140	2.17	1.50	.96	.36
EUHU2816	160	2.61	1.50	1.21	.42
EUHU2818	180	2.88	1.50	1.35	.47

Standard lengths of TIVAR profiles are 120".
Standard profile color is green.

Type TD • For Double Strand ANSI Standard Roller Chain

Catalog No.	ANSI Chain #	B	T	W	t	E	FIG.
EUHU2925	25-2	.78	.59	.10	.09	.15	A
EUHU2935	35-2	.78	.59	.17	.10	.23	A
EUHU2940	40-2	.85	.59	.29	.10	.27	B
EUHU2950	50-2	1.07	.59	.35	.12	.37	B
EUHU2960	60-2	1.34	.59	.47	.15	.40	B
EUHU2980	80-2	1.75	.71	.60	.18	.55	B

Also available for triple strand chain.
Standard lengths of TIVAR profiles are 120".
Standard profile color is green.

Conveying Components

UltraTrac Chain Guides

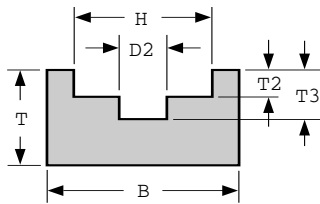
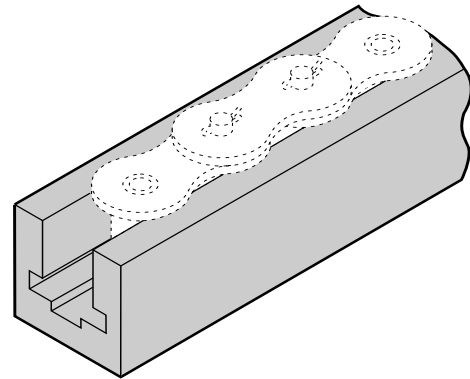

Type U

Type U • For ANSI Standard Roller Chain

Catalog No.	ANSI Chain #	B	T	T2	T3	D2	H
EUHU3025	25	.78	.59	.09	.13	.12	.27
EUHU3035	35	.78	.59	.15	.22	.16	.39
EUHU3040	40	.78	.59	.18	.26	.21	.51
EUHU3050	50	1.10	.71	.24	.35	.28	.67
EUHU3060	60	1.10	.71	.28	.41	.32	.78
EUHU3080	80	1.50	.79	.30	.47	.43	1.04

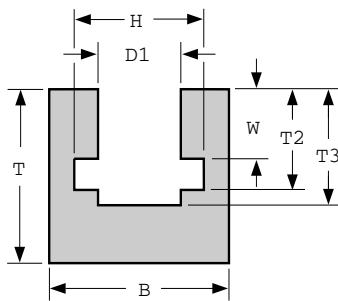

Type K

Type K • For ANSI Standard Roller Chain

Catalog No.	ANSI Chain #	B	T	W	T2	T3	D1	H
EUHU3125	25	.78	.88	.10	.20	.24	.15	.27
EUHU3135	35	.78	.88	.17	.32	.40	.22	.39
EUHU3140	40	1.10	1.05	.29	.45	.52	.33	.51
EUHU3150	50	1.50	1.43	.35	.55	.61	.42	.67
EUHU3160	60; 60H	1.50	1.85	.47	.76	.88	.49	.78
EUHU3180	80; 80H	1.50	2.45	.60	.96	1.19	.65	1.04

Conveying Components

UltraTrac Chain Guides with Steel Profiles

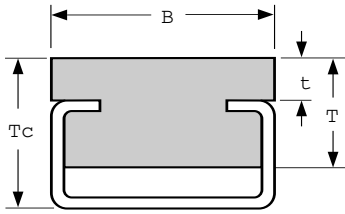

Type CF

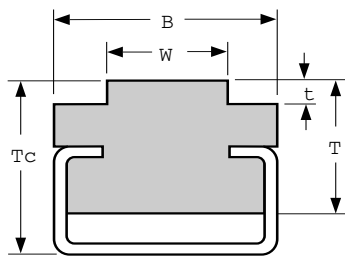

Type CT

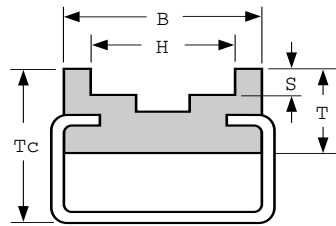

Type CU

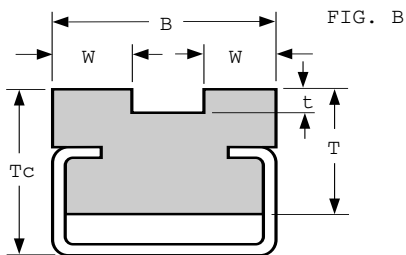
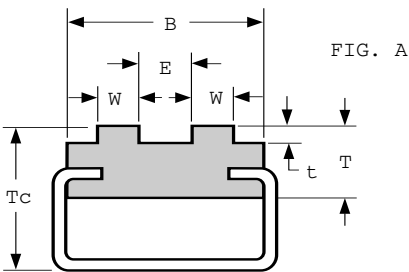

Type CTD

Type CF • Flat Profile

Catalog No.	Metal Profile	T	Tc	B	t
EUHU3201	C3	.59	.79	0.78	.40
EUHU3202	C5	.79	1.03	1.10	.56
EUHU3203	C9	.79	1.16	1.50	.45
EUHU3204	C5	.39	.63	1.10	.16

Standard lengths of TIVAR profile and steel C-Channel are 120".

Type CT • For ANSI Standard Roller Chain

Catalog No.	ANSI Chain #	Metal Profile	T	Tc	B	W	t
EUHU3325	25	C3	.59	.79	.78	.10	.09
EUHU3335	35	C3	.59	.79	.78	.17	.10
EUHU3340	40	C3	.59	.79	.78	.29	.10
EUHU3350	50	C3	.59	.79	.78	.35	.12
EUHU3360	60	C5	.59	.79	1.10	.46	.15
EUHU3380	80	C5	.71	.95	1.34	.60	.18

Standard lengths of TIVAR profile and steel C-Channel are 120".

Type CU • For ANSI Standard Roller Chain

Catalog No.	ANSI Chain #	Metal Profile	T	Tc	B	H	S
EUHU3525	25	C3	.59	.79	.78	.27	.09
EUHU3535	35	C3	.59	.79	.78	.39	.15
EUHU3540	40	C3	.59	.79	.78	.51	.18
EUHU3550	50	C5	.71	.95	1.10	.67	.24
EUHU3560	60	C5	.71	.95	1.10	.78	.28
EUHU3580	80	C9	.79	1.16	1.50	1.04	.30

Standard lengths of TIVAR profile and steel C-Channel are 120".

Type CTD • For Double Strand ANSI Standard Roller Chain

Catalog No.	ANSI Chain #	C-Profile	T	Tc	B	W	t	E	FIG.
EUHU3425	25-2	C3	.59	.79	.78	.10	.09	0.15	A
EUHU3435	35-2	C3	.59	.79	.78	.17	.10	0.23	A
EUHU3440	40-2	C3	.59	.79	.85	.29	.10	-	B
EUHU3450	50-2	C5	.59	.79	1.06	.35	.12	-	B
EUHU3460	60-2	C5	.59	.79	1.34	.47	.15	-	B
EUHU3480	80-2	C9	.71	.95	1.75	.60	.18	-	B

Also available for triple strand chain.

Standard lengths of TIVAR profile and steel C-Channel are 120".

Conveying Components

UltraTrac Chain Guides with Steel Profiles

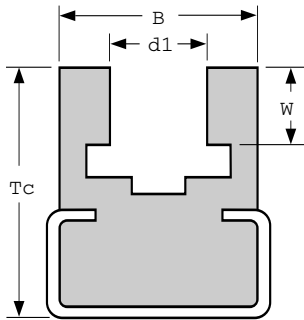
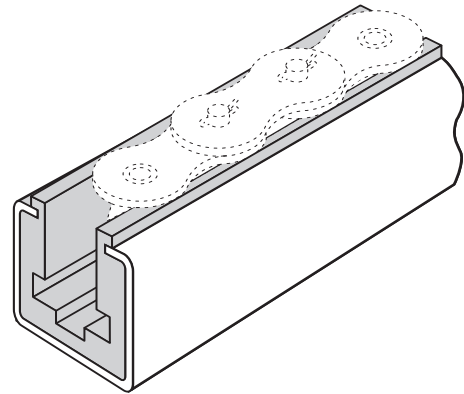

Type CK

Type CK • For ANSI Standard Roller Chain

Catalog No.	ANSI Chain #	Metal Profile	Tc	B	W	d1
EUHU3625	25	C3	.94	.78	.10	.15
EUHU3635	35	C3	.94	.78	.17	.22
EUHU3640	40	C5	1.13	1.10	.29	.33
EUHU3650	50	C9	1.53	1.50	.35	.42
EUHU3660	60	C9	1.95	1.50	.47	.49
EUHU3680	80	C9	2.55	1.50	.60	.65

Standard lengths of TIVAR profile and steel C-Channel are 120".

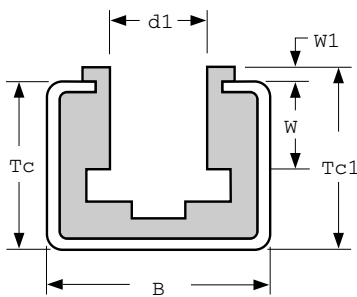

Type CKG

Type CKG • For ANSI Standard Roller Chain

Catalog No.	ANSI Chain #	Metal Profile	Tc	Tc1	B	W	W1	d1
EUHU3725	25	C9	.71		1.50	.10		.15
EUHU3735	35	C10	.94		1.18	.17		.22
EUHU3740	40	C10	.94		1.18	.29		.33
EUHU3750	50	C10	.94		1.18	.35		.42
EUHU3760	60	C10		1.02	1.18		.47	.49
EUHU3761	60	C11	1.58		1.77	.47		.49
EUHU3780	80	C11	1.58		1.771	.60		.65

Standard lengths of TIVAR profile and steel C-Channel are 120".

Conveying Components

UltraTrac belt guides

TIVAR belt guides are an excellent low-friction surface for rubber and urethane, belts or cables.

TIVAR belt guides are also available in metric sizes for round and V-belts.

Belt guides are available with or without steel profiles.

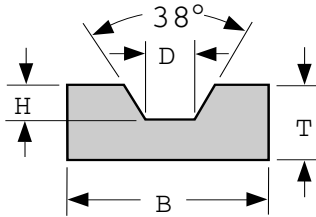

Type V

Type V • TIVAR V-Belt Guides

Catalog No.	Belt	T	B	D	H
EUHU2208	M	.38	.75	.25	.13
EUHU2210	Z	.38	.75	.28	.19
EUHU2213	A	.50	.75	.38	.25
EUHU2217	B	.63	1.25	.47	.31
EUHU2220	-	.75	1.25	.53	.38
EUHU2222	C	.75	1.38	.56	.44
EUHU2225	-	1.00	1.50	.66	.50

Standard in TIVAR 1000. Other materials available upon request.

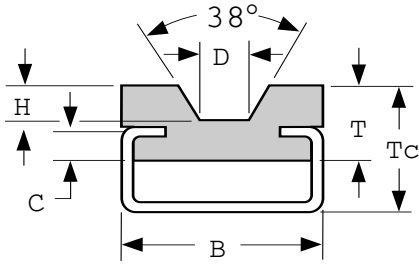

Type CV

Type CV • V-Belt Guide for Galvanized Steel Profile

Catalog No.	Belt	Metal Profile	T	B	C	Tc	D	H
EUHU1425	M	C3	.59	.78	.19	.79	.25	.13
EUHU1428	Z	C3	.59	.78	.19	.79	.28	.19
EUHU1438	A	C3	.59	.78	.19	.79	.38	.25
EUHU1447	B	C5	.81	1.10	.22	1.04	.47	.31
EUHU1453	-	C5	.81	1.10	.22	1.04	.53	.38
EUHU1456	C	C5	.81	1.10	.22	1.04	.56	.44
EUHU1466	-	C9	1.00	1.50	.33	1.38	.66	.50

Also available with stainless steel C-Profile.

Standard in TIVAR 1000. Other materials available upon request.

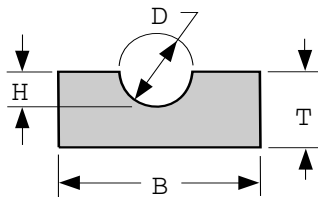

Type R

Type R • TIVAR Round Belt Guide

Catalog No.	Belt	T	B	D	H
EUHU2005	3/16	.38	.75	.25	.13
EUHU2006	1/4	.38	.75	.31	.16
EUHU2008	5/16	.50	0.75	.38	.19
EUHU2010	3/8	.63	1.00	.44	.22
EUHU2012	1/2	.75	1.25	.56	.28
EUHU2015	5/8	1.00	1.25	.69	.35
EUHU2018	3/4	1.00	1.50	.81	.41

Standard in TIVAR 1000. Other materials available upon request.

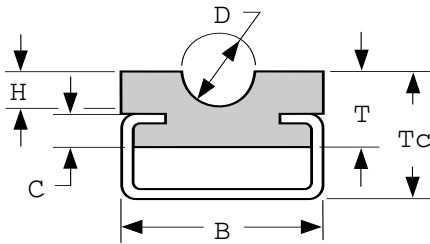

Type CR

Type CR • Round Belt Guide for Galvanized Steel Profile

Catalog No.	Belt	Metal Profile	T	B	C	Tc	D	H
EUHU1125	3/16	C3	.59	.78	.19	.79	.25	.13
EUHU1131	1/4	C3	.59	.78	.19	.79	.31	.16
EUHU1138	5/16	C3	.59	.78	.19	.79	.38	.19
EUHU1144	3/8	C5	.59	1.10	.27	.79	.44	.22
EUHU1156	1/2	C5	.59	1.10	.22	.79	.56	.28
EUHU1169	5/8	C5	.75	1.10	.22	.94	.69	.35
EUHU1181	3/4	C5	1.00	1.10	.33	1.25	.81	.41

Also available with stainless steel C-Profile

Standard in TIVAR 1000. Other materials available upon request.

Conveying Components

UltraTrac steel profiles

UltraTrac profiles are sold only in complete assemblies with TIVAR chain guide or belt guide inserts.

Standard profile lengths are 120".

Right for your environment. UltraTrac profiles are available in both stainless steel (for food handling) and galvanized steel.

Easy, economical mounting. Simply screw or weld UltraTrac profiles into place.

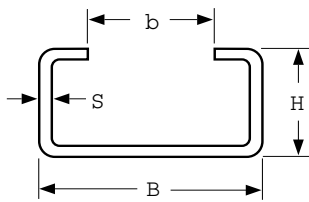
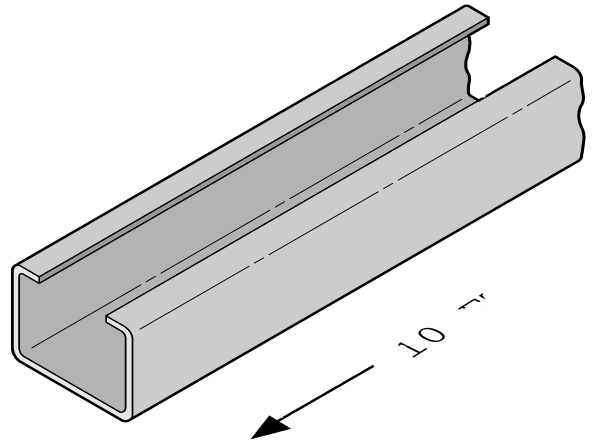

Channel #
C3, C5, C9

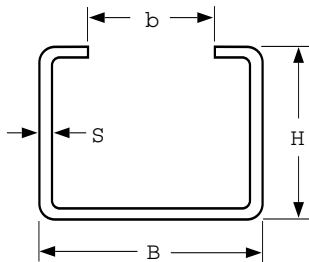

Channel #
C10, C11

Galvanized Steel C-Profile 10 ft. lengths

Profile No.	B	b	H	S
C3	0.780	0.390	0.390	0.060
C5	1.100	0.550	0.470	0.075
C9	1.500	0.870	0.710	0.100
C10	1.180	0.790	0.940	0.060
C11	1.772	1.220	1.575	0.079

304 Stainless Steel C-Profile 10 ft. lengths

Profile No.	B	b	H	S
C3	0.780	0.390	0.390	0.060
C5	1.100	0.550	0.470	0.075
C9	1.500	0.870	0.710	0.100
C10	1.180	0.790	0.940	0.060
C11	1.772	1.220	1.575	0.079

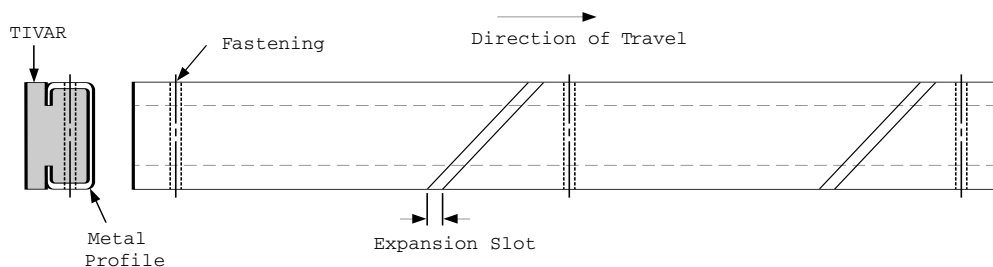

Mounting tip: Remember the effects of heat when you plan for assemblies of steel and plastic materials. The assembly suggested above accommodates the relatively large linear expansion coefficient of plastic materials. As a rule, the expansion for TIVAR = .0001 inches/inch/°F. In cases of large temperature fluctuations, we recommend using short slide rails to minimize the width of slots. Slide rails should be fastened to the C-channel to prevent displacement in the direction of travel as illustrated above.

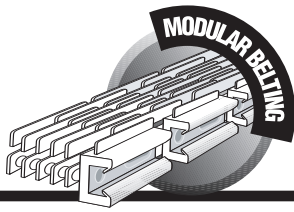

Conveyor Components

TIVAR Guide Rails and Wearstrips

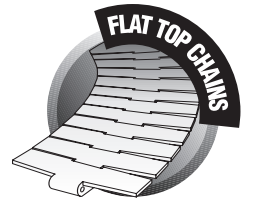
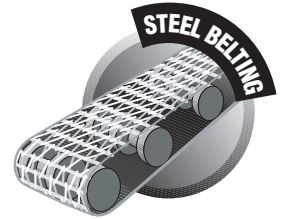

TIVAR Guide Rails and Wearstrips / J-Leg Design

Excellent for:

- Modular belts
- Steel grate bakery chains
- Flat top conveyor chains

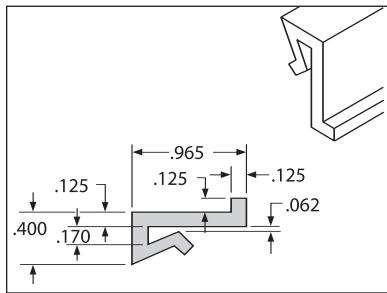
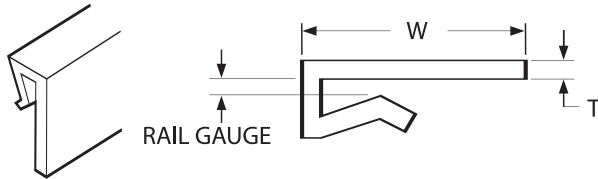

EPP634

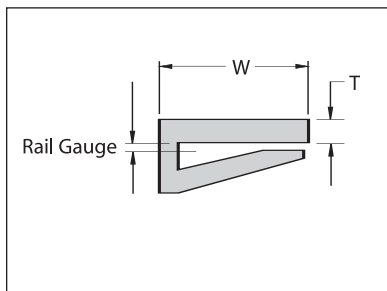

EPP861

Extruded Clip-On Wear Strips (J-Leg)

Catalog No.	T	W	Stock Lengths
EPP601	3/16	3/4	Non-Stock
EPP602	3/16	1	10' 20' 100'
EPP636	3/16	1-1/2	10' 20'
EPP603	3/16	2	10' 20'
EPP604	3/16	2-1/2	Non-Stock
EPP605	3/16	2-7/8	10' 20'
EPP606	3/16	3	10' 20'
EPP620	1/8	3/4	10' 20'
EPP621	1/8	1	10' 20'
EPP622	1/8	1-1/2	10' 20'
EPP623	1/8	2	10' 20'
EPP624	1/4	3/4	10' 20'
EPP625	1/4	1	10' 20'
EPP626	1/4	2	10' 20'
EPP627	1/4	2-7/8	Non-Stock
EPP628	1/4	3	10' 20'
EPP634	1/8	15/16	Non-Stock
EPP861	1/8	3/4	Non-Stock

Fits 12 gauge rail size



Conveyor Components

TIVAR Guide Rails and Wearstrips / Snap-ons

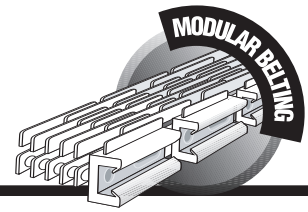

Bar Snap-On

Catalog No.	Stock Lengths (ft.)
EPP801	10' 100' 250' 500' Coils
EPP802	10' 100'
EPP803	10' 100' 250' 500' Coils
EPP804	10' 100' 250' Coils
EPP805	Non-Stock
EPP806	10' 100' Coils
EPP850	Non-stock
EPP851	10' 100' 250' Coils

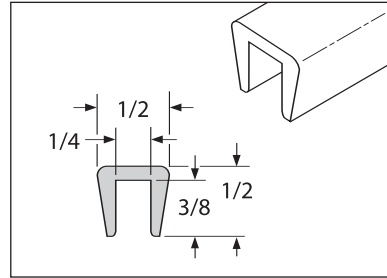

EPP801 • 1/4"

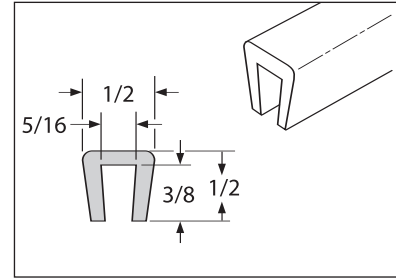

EPP802 • 5/16"

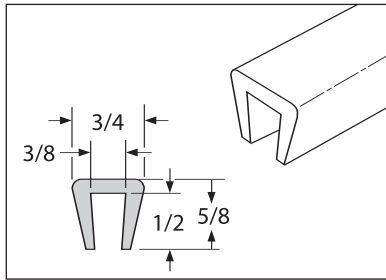

EPP803 • 3/8"

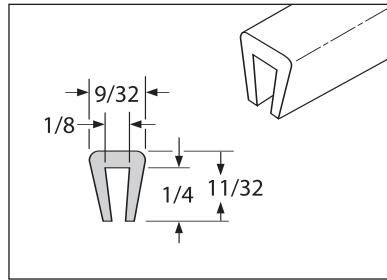

EPP804 • 1/8"

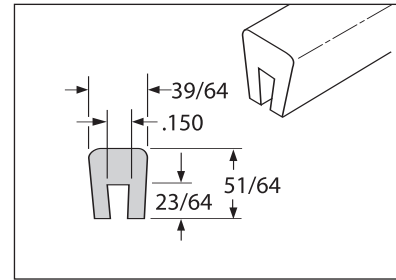

EPP805 • 13/64"

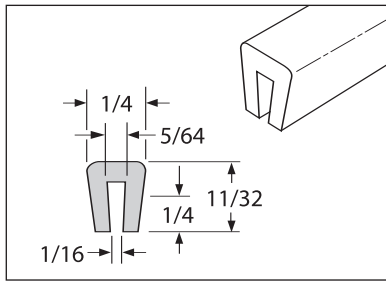

EPP806 • 5/64"

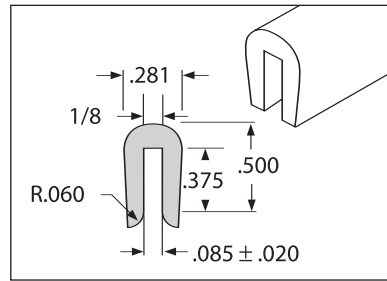

EPP850 • 1/8"

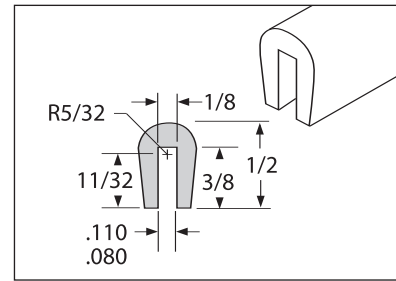

EPP851 • 1/8"

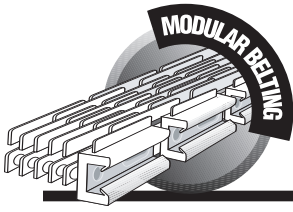

Conveyor Components

TIVAR Guide Rails and Wearstrips / WearMax

WearMax

Catalog No.	Stock Lengths (ft.)
EPP824	Non-Stock
EPP825	Non-Stock
EPP834	10'

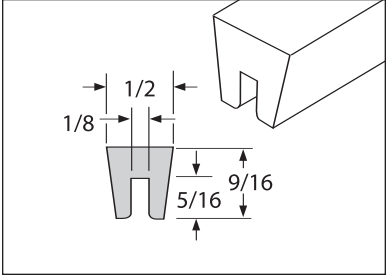

EPP824 • 1/8"

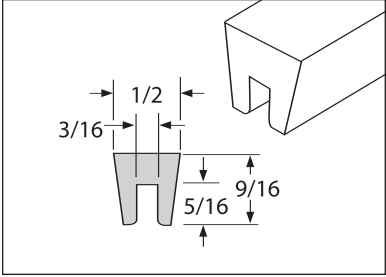

EPP825 • 3/16"

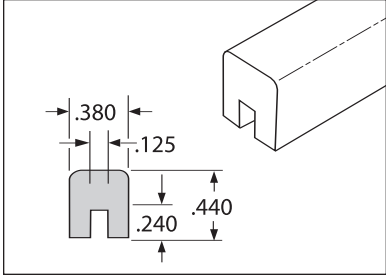

EPP834 • 1/8"

Conveyor Components

TIVAR Guide Rails and Wearstrips / C-Channels



Standard stock is TIVAR 1000 natural.

Also available in other premium TIVAR formulations.

Guide Rail Snap-On

Catalog No.	Available Lengths (Feet)
EPP702	10' 20'
EPP703	10' 20'
EPP704	10' 20'
EPP705	10' 20'
EPP707	10' 20'
EPP708	10'

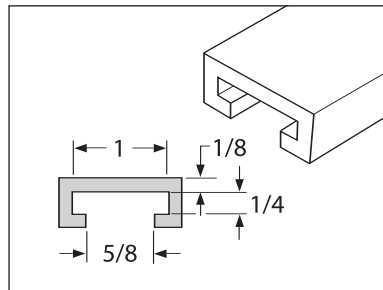

EPP702 • 1/4" x 1"

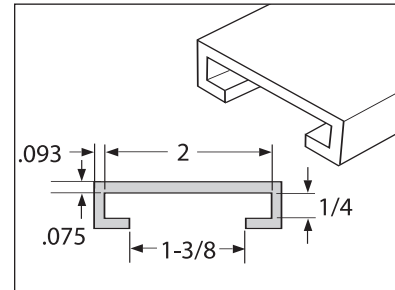

EPP703 • 1/4" x 2"

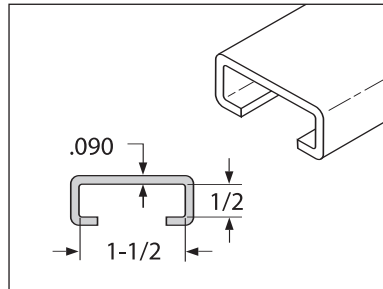

EPP704 • 1/2" x 1-1/2"

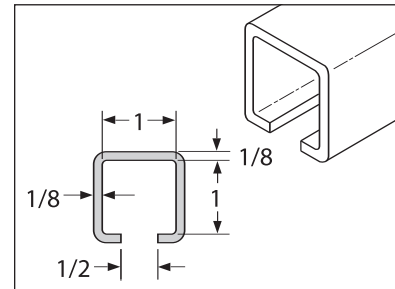

EPP705 • 1" x 1"

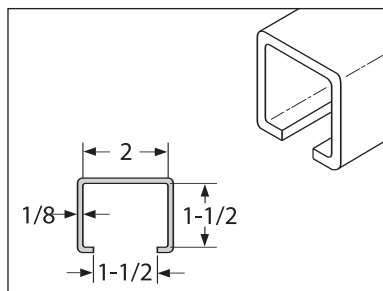

EPP707 • 1-1/2" x 2"

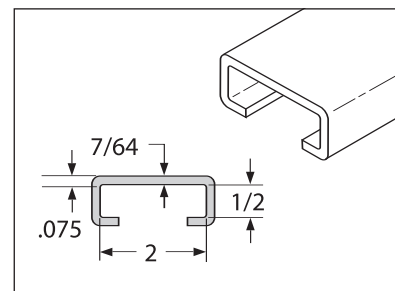

EPP708 • 1/2" x 2"



Conveyor Components

TIVAR Guide Rails and Wearstrips / C-Channels

Guide Rail Snap-On

Catalog No.	Stock Lengths (ft.)
EP401	10'
EPP903	10' 20'
EPP706	10'
EPP904	10' 20'
EPP951	10' 50'

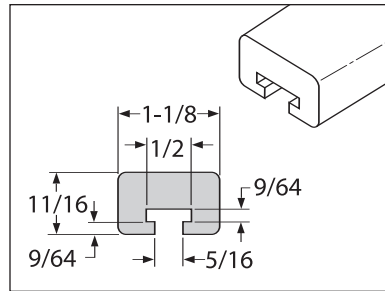

EP401 • 9/64" x 1-1/8"

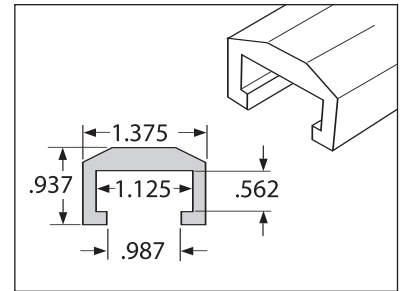

EPP706 • .562" x 1.125"

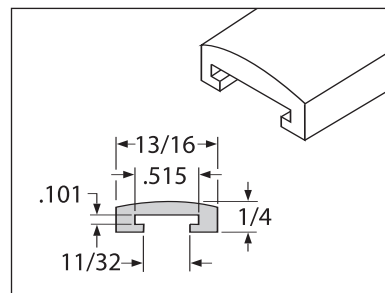

EPP903 • .101" x .515"

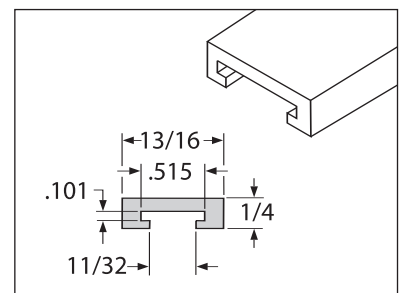

EPP904 • .101" x 13/16"

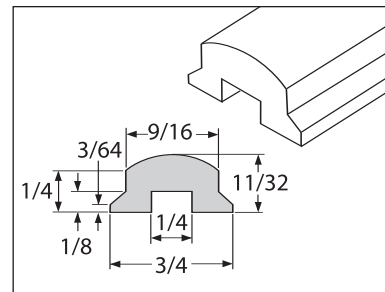

EPP951 • 1/8" x 1/4"

Conveyor Components

TIVAR Guide Rails / Full Rounds and Half Rounds



Full Round

Catalog No.	Stock Lengths (Feet)
EPP350	10'
EPP351	10' 100' 250' Coils
EPP352	10' 100' Coils

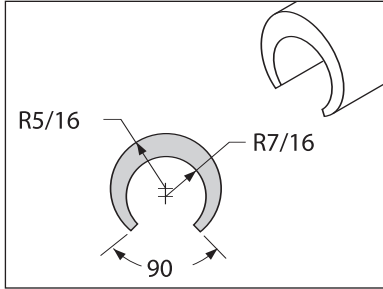

EPP350 • 5/8"

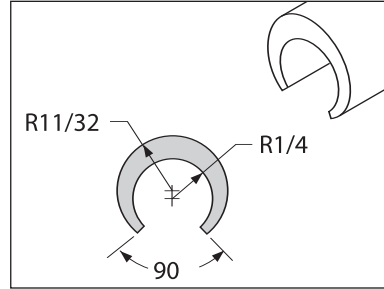

EPP351 • 1/2"

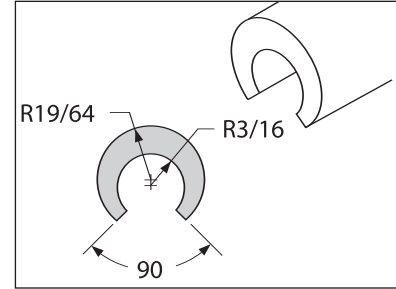

EPP352 • 3/8"

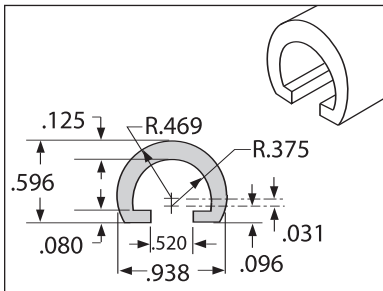

EPP300 • 3/4"

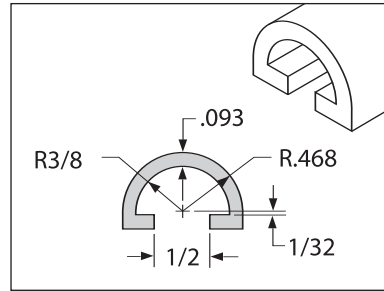

EPP301 • 3/4"

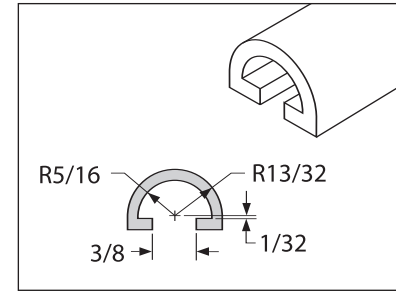

EPP302 • 5/8"

Half Round

Catalog No.	Stock Lengths (Feet)
EPP300	Non-Stock
EPP301	10' 100' 250' Coils
EPP302	10' 100' 250' Coils
EPP303	10' 100' Coils

Half Round With Flat

Catalog No.	Stock Lengths (Feet)
EPP304	10'

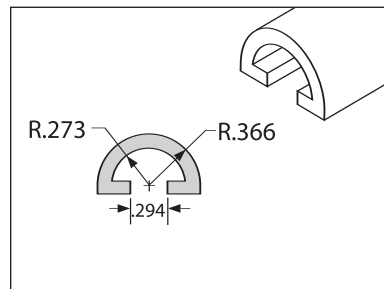

EPP303 • 1/2"

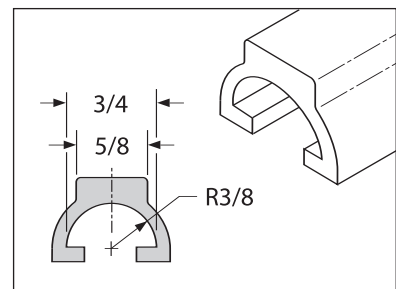

EPP304 • 3/4" F

Conveyor Components

TIVAR Guide Rails & Wearstrips / U-Channels, Right Angles & Dogbones

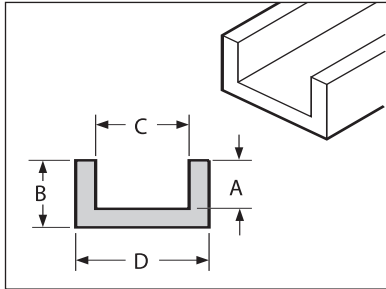

U-Channels

U-Channels

Catalog No.	A (Inches)	B (Inches)	C (Inches)	D (Inches)	Stock Lengths (ft.)
EP101	7/8	1-1/4	3-1/2	4-1/4	10' 20'
EP102	5/8	1	2-1/2	3	10' 20'
EP103	5/8	1	2	2-1/2	10'
EP104	5/8	1	1-1/2	2	10'
EP105	1/2	7/8	1	1-1/2	10'
EP106	3/8	3/4	1/2	1	10'
EP111	5/8	1	2-1/4	3	10'
EP112	0.605	0.730	1	1-1/4	10'
EP113	3/4	1	0.45	1	Non-Stock

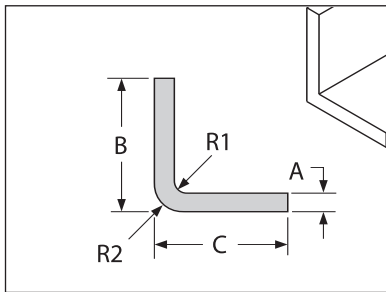

Right Angle

Right Angles

Catalog No.	A	R1	B	R2	C	Stock in Lengths (ft.)
EP201	1/4	.100	1-1/2	.125	1-1/2	10'
EP202	1/4	.040	2	.156	2	10'
EP203	1/2	.094	3	.250	3	10'
EP208	1/2	—	3-1/2	.250	3-1/2	10'
EP210	1/4	1/16	5/8	1/8	1-1/2	10'
EP220	1/8	.093	1	.140	1	Non-Stock
EP221	1/8	.093	1-1/2	.140	1-1/2	Non-Stock
EP222	1/8	.093	2	.140	2	Non-Stock

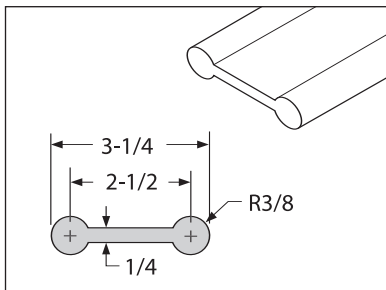

Dogbone Wearstrip
EP501 • 3/4" x 3-1/4"

Dogbone Wearstrip

Catalog No.	Stock Lengths (Feet)
EP501	10'

Semi-Finished Product

TIVAR Board Stock

TIVAR Extruded Tape & Board - Natural White

Part No.	Thickness (In.)	Width (In.)
EP1006	1/10	3
EP2005	.219	2-1/2
EP3005	1/4	2
EP3006	1/4	3
EP3007	1/4	4
EP3010	1/4	7
EP4003	3/8	1
EP4005	3/8	2-5/8
EP4006	3/8	3
EP5007	1/2	4
EB5008	1/2	5
EB5009	1/2	6
EP5010	1/2	7
EB5015	1/2	12
EB7006	1	3
EB7008	1	5
EB7017	1	14
EB7101	1-1/8	2-5/8
EB7102	1-1/8	3-1/4
EB7103	1-1/8	4-1/8
EB7201	1-1/4	2-1/4
EB7219	1-1/4	16
EB7508	1-1/2	5
EB7511	1-1/2	8
EB7513	1-1/2	10
EB7517	1-1/2	14
EB8011	2	8
EB8013	2	10
EB8017	2	14
EB8022	2	20
EB8512	2-1/2	9
EB8529	2-1/4	26

Coils are available in all 1/4" board sizes and smaller. Other sizes up to 40 ft. lengths. Minimums may apply



Semi-Finished Product

TIVAR Rod and Tube

Many TIVAR extruded rods and tubes are sized to allow for machining to a given diameter.

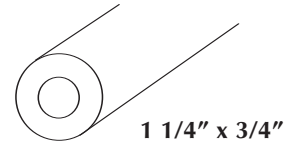

Excellent for

- Bearings and bushings
- Rollers
- Gears
- Cams and cam guide parts
- Timing and feed screws



Available in

- TIVAR 1000 natural and premium formulations
- Color matched in 14 standard colors for timing and feed screws

Extruded Rod

Part No.	Dimensions in Diameter
ER50	.250
ER60	.375
ER69	.500
ER70	.625
ER71	.750
ER73	1.000
ER74	1.250
ER741	1.375
ER75	1.500
ER76	1.750
ER77	2.000
ER78	2.250
ER781	2.375
ER79	2.500
ER80	2.750
ER81	3.000
ER82	3.250
ER83	3.500
ER84	3.750
ER85	4.000
ER86	4.250
ER87	4.500
ER88	5.000
ER89	5.500
ER90	6.000
ER91	6.500
ER92	7.000
ER94	8.000
ER96	9.000
ER98	10.000

Extruded Tubing

Part No.	Dimensions in Inches Size (ODxID)	
ET080	.875	x .250
ET085	.875	x .375
ET100	1.000	x .500
ET101	1.000	x .750
ET102	1.000	x .625
ET103	.750	x .375
ET111*	1.000	x .563
ET124	1.250	x .750
ET125	1.250	x .625
ET126*	1.250	x .563
ET127	1.250	x 1.000
ET130	1.375	x .625
ET131	1.375	x .750
ET132	1.375	x 1.000
ET151	1.500	x .500
ET152	1.500	x 1.000
ET154	1.500	x 1.125
ET160	1.625	x 1.250
ET180	1.875	x 1.125
ET181	1.875	x 1.250
ET200	2.000	x 1.000
ET201	2.000	x 1.500
ET202	2.000	x 1.250
ET203	2.000	x 1.750
ET204	2.000	x 1.375
ET210	2.250	x 1.750
ET202	2.250	x 1.875
ET230	2.375	x 1.750
ET251	2.500	x 1.500
ET252	2.500	x 2.000
ET253	2.500	x 1.000
ET260	2.625	x 2.250
ET270	2.750	x 2.000
ET300	3.000	x 2.000
ET301	3.000	x 2.500
ET310	3.125	x 2.750
ET350	3.500	x 2.500
ET351	3.500	x 3.000
ET400	4.000	x 3.000
ET401	4.000	x 3.500
ET451	4.500	x 4.000
ET500	5.000	x 4.000
ET501	5.000	x 4.500
ET549*	5.500	x 4.375
ET551	5.500	x 4.750
ET625	6.250	x 5.750
ET860	8.625	x 7.875
ET950*	9.500	x 8.250

*Non-Stock. Minimums may apply.